

HIGH
SPEED
DOORS



DynamicRoll®

TECHNICAL DATA



SELF-REPAIR



SAFE



HERMETIC

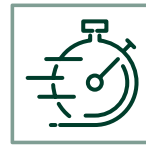

HIGH SPEED

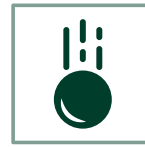

GRAVITY TECHNOLOGY

DYNAMICROLL® is a self-repairing roll up door designed to reach different kinds of applications, both internal and external, allowing the traffic flows and assuring high safety.



MAXIMUM DIMENSIONS	W 8000 mm x H 8000 mm
FUNCTIONING	AUTOMATIC
CYCLES PER HOUR	> 200
CYCLES TEST	1.000.000
SPEED	Up to 2,5 m/s
OPTIONAL SPEED	Up to 3 m/s
WIND RESISTANCE* <i>DIFFERENTIAL PRESSURE</i>	Ut to Class 4 EN 12424
WIND SPEED DURING DOOR OPENING	< 20 m/s (60 km/h)
SOUNDPROOFING <i>STANDARD</i>	15 dB Rw (ISO 717)
WATER RESISTANCE	0,11 kPa for <i>door closed</i> Class 3 - EN12426
OPERATING TEMPERATURE OPERATING ENVIRONMENT	-10°C to +70°C

*This door, according to the regulations 13241/CE, requires an half-yearly check

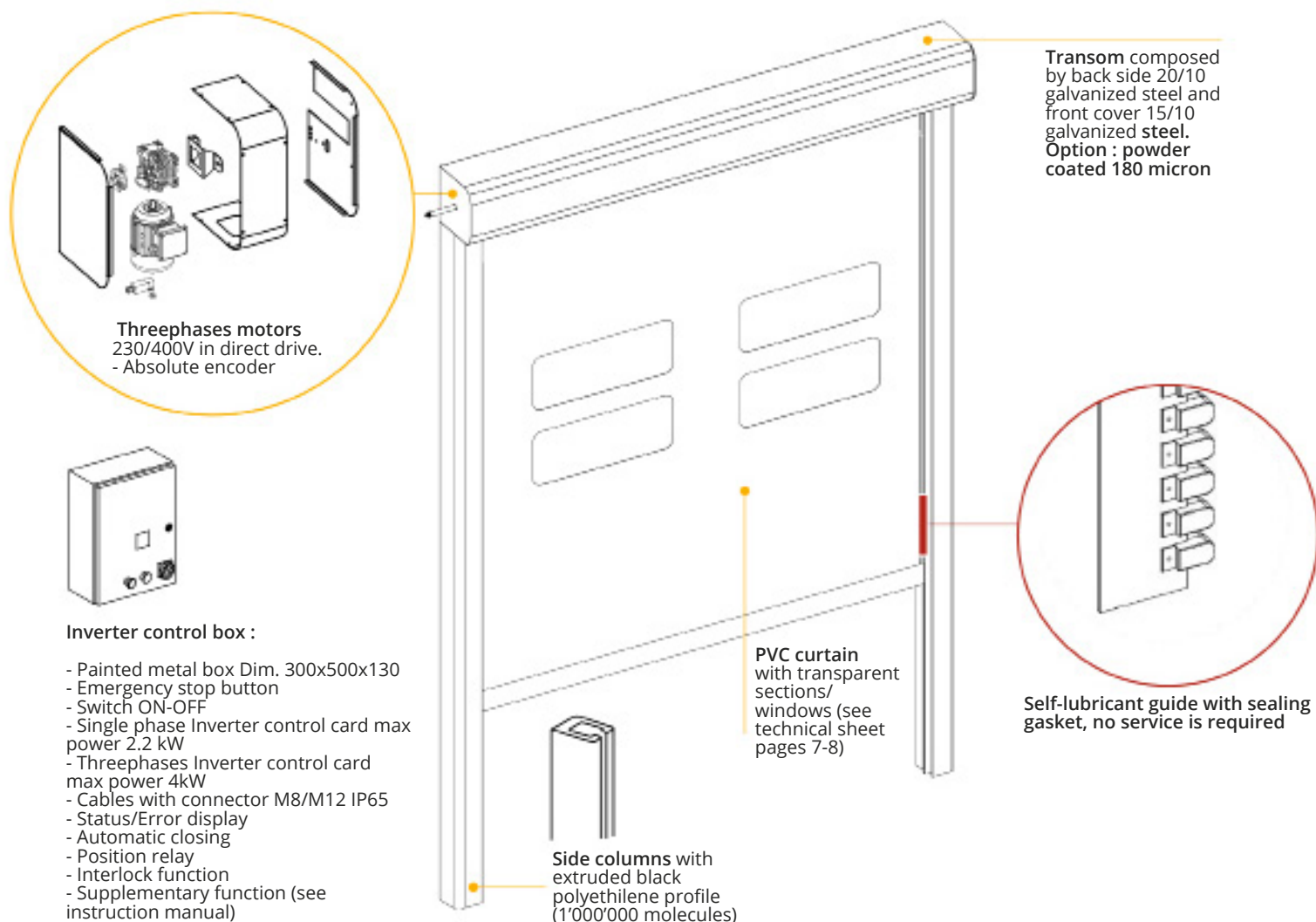

SEALING SYSTEM

SIDE SECTION

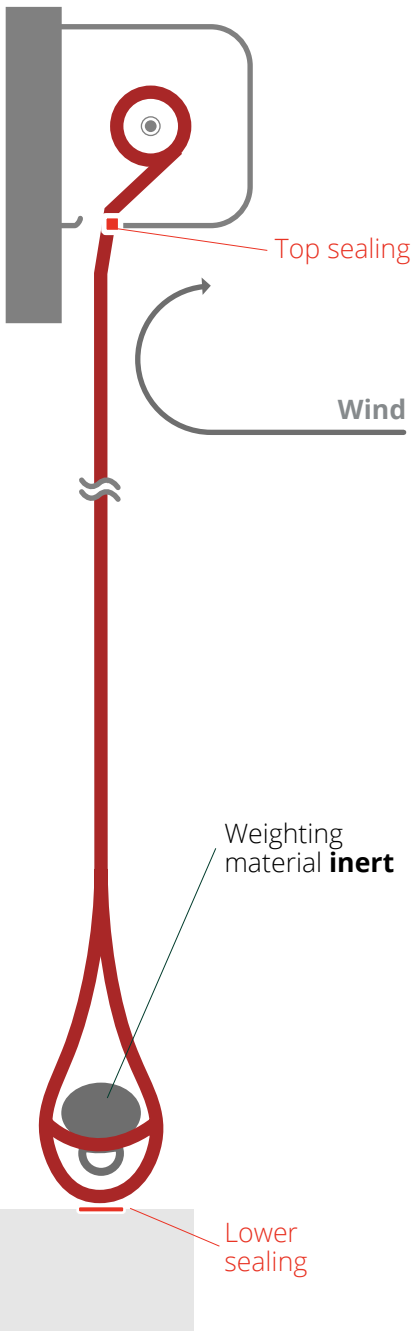

SAFE SYSTEM

1 Wireless option

SIDE SECTION

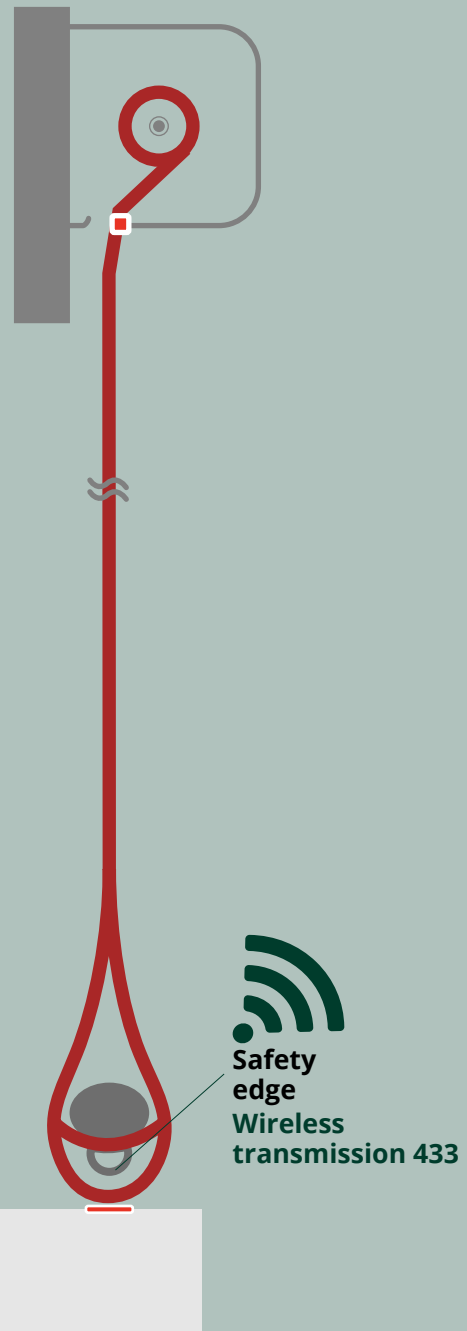

2 Light barriers

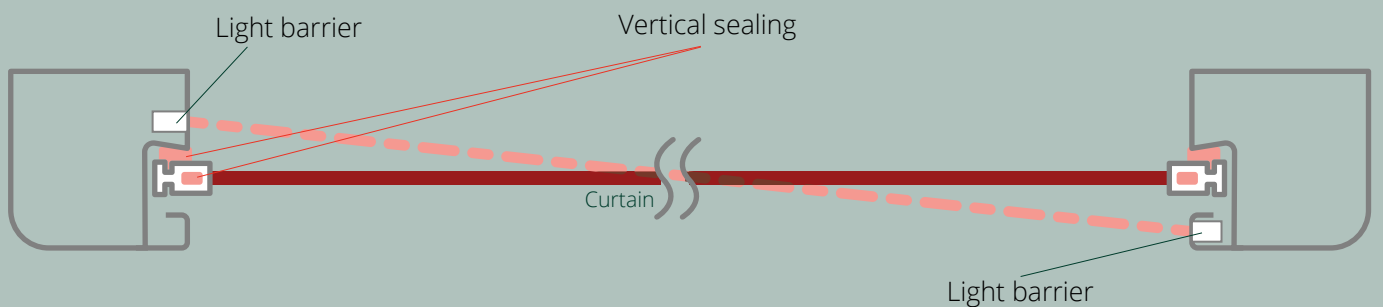

OVERALL DIMENSIONS

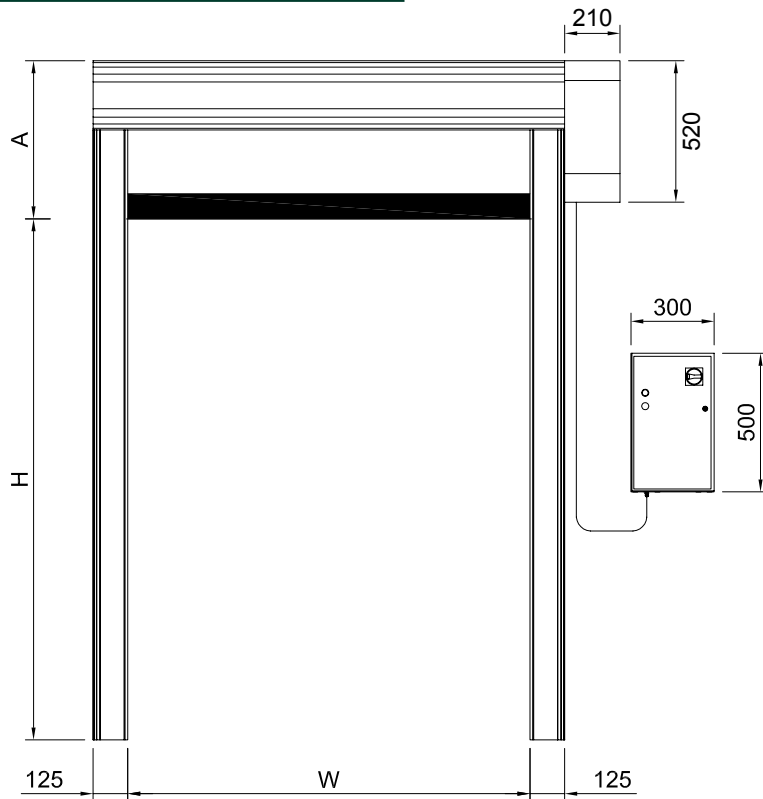

A: 450 / 500 / 550 / 650

MOUNTING METHOD

Reveal fit mounting

In case of reveal fit, columns must be supported by 120x40 vertical galvanized steel profile supplied with the door. It's possible to mount the frontal motor.

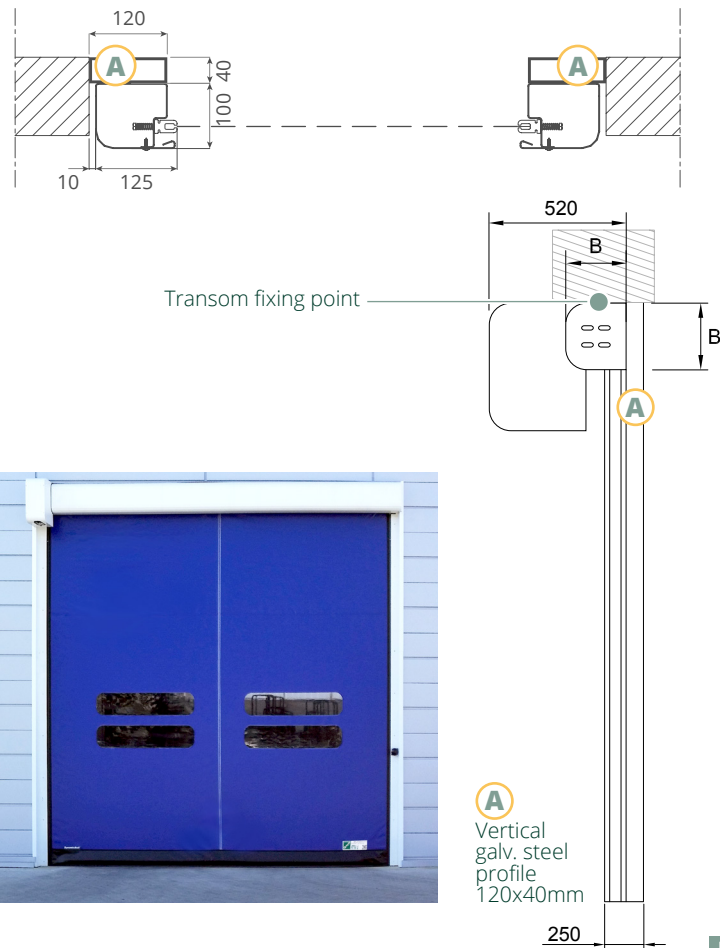

A
Vertical galv. steel profile 120x40mm

250

Face fit mounting

In case of face fit, columns are fixed direct to the existing wall. Make sure there is an appropriate support.

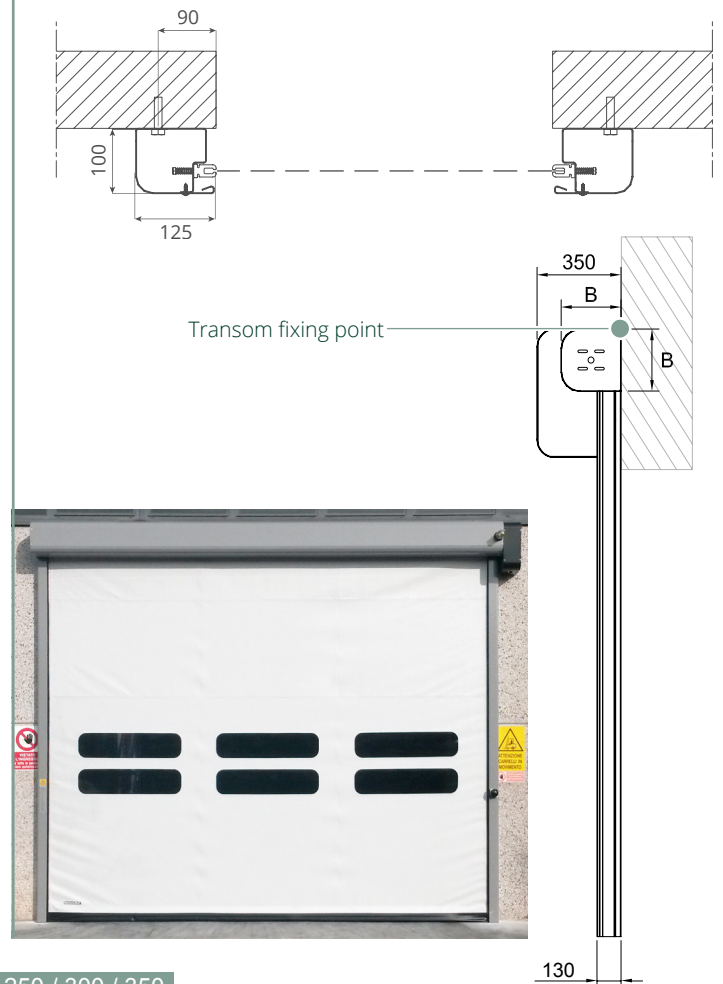

B: 250 / 300 / 350

130

PVC CHARACTERISTICS

STANDARD PVC

Composition and tests

EXTERNAL SIDE			
Material	Finishing	Color	Thick
PVC	Opaque	12 standard	0,7 mm
FABRIC			
Material	N. tarps	Title	EN 2286-2
PES	1	1100Dtex 12x12	900 g/m ²
INTERNAL SIDE			
Material	Finishing	Color	Thick
PVC	Rough	12 standard	0,2 mm
COLD RESISTANCE ISO 4675/90 -50°C ±5			
HYDROLYSIS TEST 75°C 95% humidity none variation			
GAS OIL TEST ISO 1421 none variation			
MARINE WATER TEST (ISO 1421) none variation			
OZONE TEST ISO 3011 none crack			
T. STORAGE (°C) -30 +65			
FLAME TEST (ISO 3795) < 100 mm/min			
PERFORATION RINA 3.A1.2.7 (N) > 100			
EXERCISE 7 days -70°C ISO 6065 none variation			

Characteristics

THICK ISO 2286/3 (mm) 0,9±0,1
WEIGHT ISO 2286/2 (kg/m ²) 0,90±0,1
LOAD BREAK ISO 1421 6000 N/50mm
WARP EXTENSION ISO 1421 4300 N/50mm
TEXTURE EXTENSION ISO 1421 4000 N/50mm
WARP BREAK dIN 53 363 (N) > 600
TEXTURE BREAK dIN 53 363 (N) > 530
ADHESION dIN EN ISO 2411 130 N/50mm
EEC CONFORMITY Yes
SPECIFIC USE industry, refrigerators, car washes, supermarkets, warehouses
ASSOCIATION -

Colors

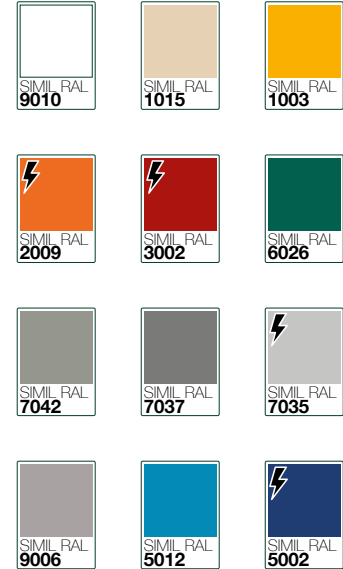

⚡ Antistatic available

INSULATED PVC

Composition and tests

EXTERNAL SIDE			
Material	Finishing	Color	Thick
PVC	Straight	4 standard	0,5 mm
FABRIC			
Material	N. tarps	Title	EN 2286-2
PES	1	1100Dtex 12x12	1350 g/m ²
INTERNAL SIDE			
Material	Finishing	Color	Thick
PVC	Sponge	4 standard	7 mm
COLD RESISTANCE ISO 4675/90 -10°C ±5			
HYDROLYSIS TEST 75°C 95% humidity none variation			
GAS OIL TEST ISO 1421 none variation			
MARINE WATER TEST (ISO 1421) none variation			
OZONE TEST ISO 3011 none crack			
T. STORAGE (°C) -30 +65			
FLAME TEST ISO 3795 cl 2, NFPA 701 test 2			
PERFORATION RINA 3.A1.2.7 (N) > 100			
EXERCISE 7 days -70°C ISO 6065 none variation			

Characteristics

THICK ISO 2286/3 (mm) 7,0±0,1
WEIGHT ISO 2286/2 (kg/m ²) 1,7±0,1
LOAD BREAK ISO 1421 6000 N/50mm
WARP EXTENSION ISO 1421/V1 3000 N/50mm
TEXTURE EXTENSION ISO 1421/V1 2800 N/50mm
WARP BREAK dIN 53 363 300 N
TEXTURE BREAK dIN 53 363 300 N
ADHESION PA 09.03 (internal) 15 N/cm
THERMAL CONDUCTIVITY 0,03782 W.m ⁻¹
ISOLATION INDEX Rw= 17,5 dB
EMPLOYMENT industry, refrigerators, car washes, supermarkets, warehouses
ASSOCIATION -

Colors

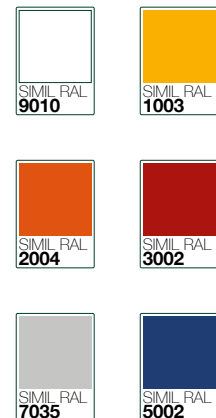

MEASUREMENT OF SOUNDPROOFING POWER
R - UNI EN ISO 10140-2 - UNI EN ISO 717-1

	Source	Receiver
Volume (m³)	86,0	70,5
Temp. (°C)	21,0	21,0
Volume (m³)	86,0	70,5
FREQ. Hz	R dB	U dB
100	14,9	1,8
125	7,5	1,7
160	8,2	1,5
200	8,7	1,6
250	8,8	1,3
315	8,6	1,2
400	10,7	1,2
500	11,7	1,1
630	13,5	1,1
800	15,4	1,1
1000	16,9	1,0
1250	18,8	1,0
1600	20,4	1,0
2000	21,2	1,0
2500	21,8	1,0
3150	22,6	1,0
4000	22,9	1,0
5000	23,0	1,0
Rw	17 dB	
C	-1 dB	
Ctr	-3 dB	
K	2,00 - 95%	

SAMPLE AREA
S = 1,50 m²

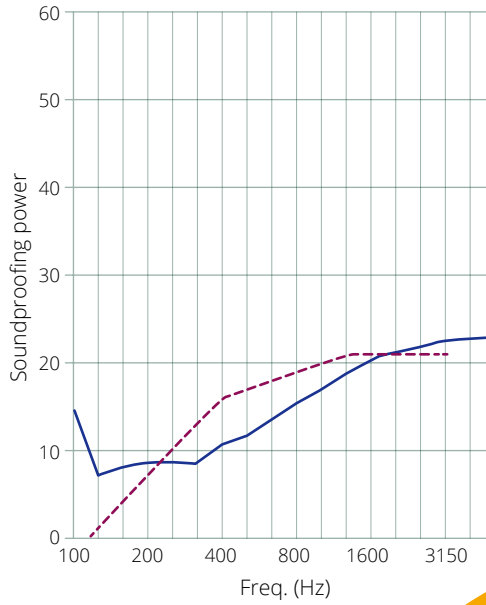

Evaluation according to ISO 717-1 in the band 100 ÷ 3150 Hz based on laboratory measurements

CRISTAL CHARACTERISTICS

PVC SUPERCLEAR

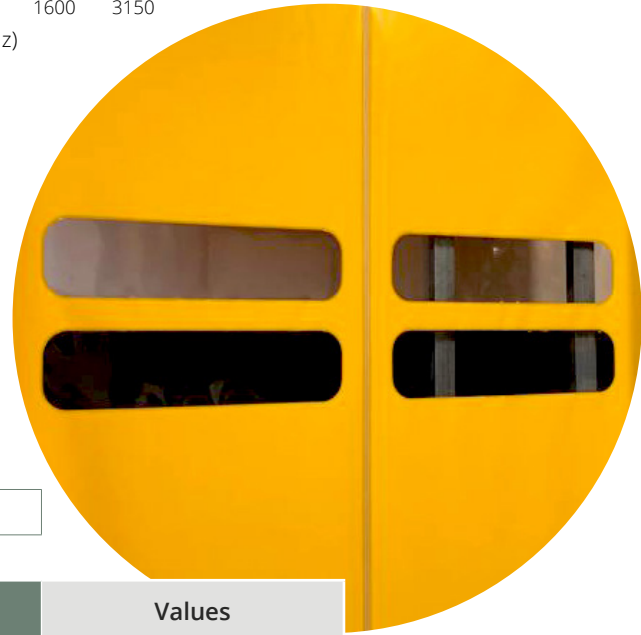

WINDOWS - CRISTAL TECHNICAL DATA

Article	SUPERCLEAR 1.2 mm FR
---------	----------------------

Technical Specifications	Standards	Unit	Values
Thickness	-	mm.	1.2
PVC total weight	-	g/m²	1200
Ligth transmission	JIS K - 7361	%	97.3
Tensile strength <i>Lenghtwise MD</i>	JIS K - 6732	N	26.1
Tensile strength <i>Crosswise TD</i>	JIS K - 6732	N	24.3
Tear strength <i>Lenghtwise MD</i>	JIS K - 6732	N	63.4
Tear strength <i>Crosswise TD</i>	JIS K - 6732	N	63.9
Elongation <i>Lenghtwise MD</i>	JIS K - 6732	%	377
Elongation <i>Crosswise TD</i>	JIS K - 6732	%	378
Cold crack resistance	JIS K - 6772	°C	-45
Flame retardancy	-	-	si
Hardness	-	-	4.0S
Standard length	-	m	30
Standard width	-	m	1.37

OPTIONAL ACCESSORIES



RADAR



OPENING POINTING RADAR
TOF/SPOT
for internal use only



INFRARED RADAR
with cross-movement
adjustment



INFRARED RADAR
motion and presence
(pedestrian/forklift) radar

TRAFFIC LIGHTS



GREEN FIXED STANDARD
traffic light



RED FIXED STANDARD
traffic light



LED TRAFFIC LIGHT
with countdown

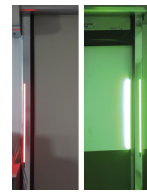

LED TRAFFIC LIGHT BARRIERS
(connection card included)

BUTTONS



OPENING GREEN BUTTON
with box



OPENING BLACK BUTTON
with box



FREEZE STOP BUTTON
with box



NO TOUCH BUTTON



TRAFFIC LIGHT
BUTTON

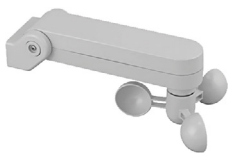

WIND
GAUGE



KEY
SELECTOR



REMOTE
CONTROL



BOLLARD
B-PROTECT



PULL CORD
SWITCH



MAGNETIC LOOP
DETECTOR



Quality products since 1997

BMP EUROPE HIGH SPEED DOORS
Strada della Freisa 1 - Villanova d'Asti 14019 (AT)
+39 0141 948843
www.bmpdoors.com - info@bampeurope.eu

07/2021